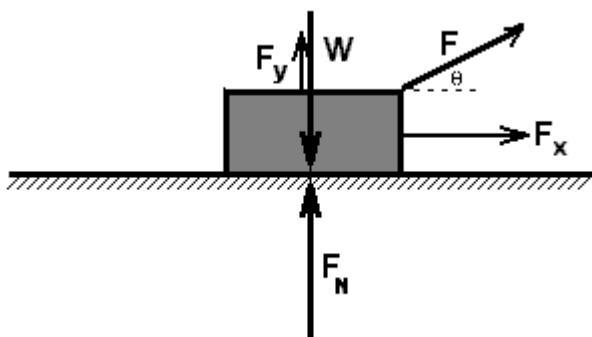

Lesson 17-Sliding Block Problems – Up Arrow

The basic features of the introductory sliding block problems are these:

- A horizontal surface (we'll get to tilted surfaces eventually)
- A block-like object that will slide but will not roll when we apply a force
- There may or may not be friction between the block and the surface. We'll start with the frictionless case first, then immediately take up the case with friction.
- A force that pulls on the block. It is not necessarily pulling parallel to the horizontal surface. The force is directed upward away from the center of mass so no torque is created.

The important concept to master in these problems is breaking the force into two components. One component must point in the direction of the motion of the block. The second component must be perpendicular to the first component. The two components must add up (as vectors) to the original force vector. When friction is not present, only the component that points in the direction of motion matters. When friction is present, both components play important roles that influence the motion.

Force Diagram for Sliding Block Problems without Friction

In this diagram, \mathbf{W} is the weight of the block due to gravity acting on it. \mathbf{F}_N is normal force from the surface pushing up on the block. \mathbf{F} is the applied force that we are using to move the block. \mathbf{F} is applied at an angle of θ to a horizontal reference line.

The horizontal and vertical components of \mathbf{F} are shown here as \mathbf{F}_x and \mathbf{F}_y , respectively. Like \mathbf{F} , each of the components is acting through the center of mass of the block. We don't usually take such care to show that the force and its components are acting through the center of mass. Even without such care in the drawing, we should understand that all the forces are acting through the center of mass of the block.

We use simple trigonometry to find the components of \mathbf{F} .

$$\mathbf{F}_x = \mathbf{F} \cos \theta$$

$$\mathbf{F}_y = \mathbf{F} \sin \theta$$

The Vertical “Sum of Forces” Equation

The block is always in vertical equilibrium. In other words, it will not accelerate perpendicular to the floor. Therefore, the sum of the vertical forces is always zero.

$$\Sigma F_V = F_N - W + F_y = 0$$

Therefore,

$$F_N = W - F_y = mg - F \sin \theta$$

The Horizontal “Sum of Forces” Equation – No Friction

There are only two possibilities. Either the block is moving at some constant velocity and the sum the horizontal forces is zero, or the block is accelerating and the sum of the horizontal forces equals mass times acceleration.

If the block is moving at constant velocity

$$\Sigma F_H = F_x = F \cos \theta = 0$$

This is a trivial case because $F_x = 0$ can only be true if the angle is 90° . When the angle is 90° , $\cos \theta = 0$, and F has no horizontal component. As long as F points straight up and is less than W the velocity of the block will remain constant with the value it had before F was applied. The value of F cannot be determined by examining the motion since a vertical force cannot affect the horizontal motion.

If the block is accelerating,

$$\Sigma F_H = F_x = ma$$

or

$$F_x = F \cos \theta = ma$$

The four solutions for the four variables are

$$a = F \cos \theta / m$$

$$m = F \cos \theta / a$$

$$F = ma / \cos \theta$$

$$\theta = \cos^{-1} (ma / F)$$

This is also a simple case since only one horizontal force is involved. If you know any three of the four variables, a , F , m , or θ , you can solve for the missing variable.

Force Diagram for Sliding Block Problems with Friction

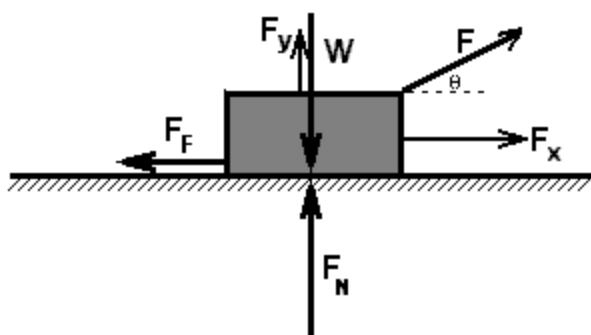

When friction is added to the problem you must begin by using the new force diagram.

This diagram is exactly like the first one except for the addition of the friction force. There are two horizontal forces in this diagram instead of only one as in the first diagram. The friction force, indicated here as F_F , can be either a static or a kinetic friction force depending on whether the

block is moving or not. If F_S is larger than F_x , the block will not be moving. When F_x is larger than F_K , the block will be moving.

The Vertical “Sum of Forces” Equation

The block is always in vertical equilibrium. In other words, it will not accelerate perpendicular to the floor. Therefore, the sum of the vertical forces is always zero. This is exactly the same result we got without friction.

$$\Sigma F_V = F_N - W + F_y = 0$$

Therefore,

$$F_N = W - F_y = mg - F \sin \theta$$

The Horizontal “Sum of Forces” Equation – With Friction

There are only three possibilities. A) The block is not moving and $\Sigma F_H = 0$. B) The block is moving at a constant velocity and $\Sigma F_H = 0$. C) The block is accelerating and $\Sigma F_H = ma$.

If the block is not moving

$$\Sigma F_H = F_x - F_S = F \cos \theta - \mu_S F_N = F \cos \theta - \mu_S [mg - F \sin \theta] = 0$$

This equation includes four variables; F , θ , μ_S , and m . You’ll need to know three of the four variables to find the missing one. The missing variable in each case represents a boundary value between moving and not moving. The four solutions for the four variables are

$$F = \mu_S mg / [\cos \theta + \mu_S \sin \theta]$$

$\theta \rightarrow$ Best found using graphical techniques. We will not assign problems to find θ .

$$\mu_S = F \cos \theta / [mg - F \sin \theta]$$

$$m = [F \cos \theta + \mu_S F \sin \theta] / [\mu_S g]$$

If the block is moving at constant velocity

$$\Sigma F_H = F_x - F_K = F \cos \theta - \mu_K F_N = F \cos \theta - \mu_K [mg - F \sin \theta] = 0$$

This equation includes four variables; F , θ , μ_K , and m . You'll need to know three of the four variables to find the missing one. The four solutions for the four variables are

$$F = \mu_K mg / [\cos \theta + \mu_K \sin \theta]$$

$\theta \rightarrow$ Best found using graphical techniques. We will not assign problems to find θ .

$$\mu_K = F \cos \theta / [mg - F \sin \theta]$$

$$m = [F \cos \theta + \mu_K F \sin \theta] / [\mu_K g]$$

If the block is accelerating,

$$\Sigma F_H = F_x - F_K = F \cos \theta - \mu_K F_N = F \cos \theta - \mu_K [mg - F \sin \theta] = ma$$

or

$$F [\cos \theta + \mu_K \sin \theta] = m [a + \mu_K g]$$

This is not a simple equation. It includes five variables; a , F , θ , μ_K , and m . You'll need to know four of them to find the fifth. The five solutions for the five variables are

$$a = [F \cos \theta + \mu_K F \sin \theta - \mu_K mg] / m$$

$$F = m[a + \mu_K g] / [\cos \theta + \mu_K \sin \theta]$$

$\theta \rightarrow$ Best found using graphical techniques. We will not assign problems to find θ .

$$\mu_K = [F \cos \theta - ma] / [mg - F \sin \theta]$$

$$m = [F \cos \theta + \mu_K F \sin \theta] / [a + \mu_K g]$$

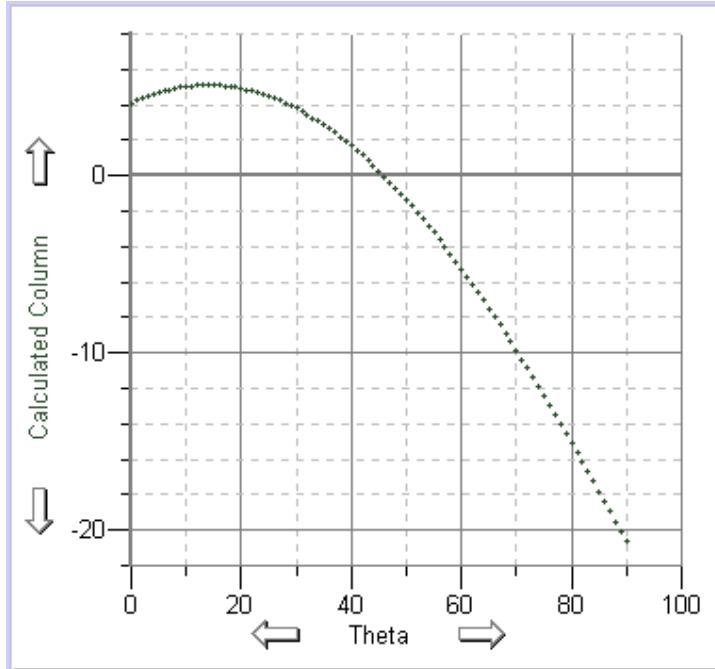

Graphical Solution for Theta

Suppose we know

$$a = 0.437946429 \text{ m/s}^2$$

$$F = 33.00 \text{ N}$$

$$\mu_F = 0.25$$

$$m = 10 \text{ kg}$$

From the analysis above we know

$$F [\cos \theta + \mu_k \sin \theta] - m [a + \mu_k g] = 0$$

Use Graphical Analysis to plot the left side of this equation vs theta. The answer is the angle where the expression crosses the theta axis, ie the angle where the expression equals zero, ie the angle where the equation is satisfied.

In this example, the graph shows the answer is between 45° and 46°. A more thorough analysis shows that the angle is approximately 45.852 749 23° in *Excel* and 45.852 749 23° in *Graphical Analysis*. You can obtain this answer by plotting the points at finer and finer intervals along the theta axis until you have enough precision to satisfy the requirements of your calculation.